

NO.	QTY.	DESCRIPTION	MATERIAL	MOUNTING	DESIGN	DENSITY	C-C	VISSIBLE	PROCESS CONNECTION	CHAMBER END TOP	CHAMBER END BOTTOM
1	2	MAGNETIC LEVEL GAUGE		SIDE-SIDE						FLANGE WITH VENT VALVE 1/2"	FLANGE WITH DRAIN VALVE 1/2"

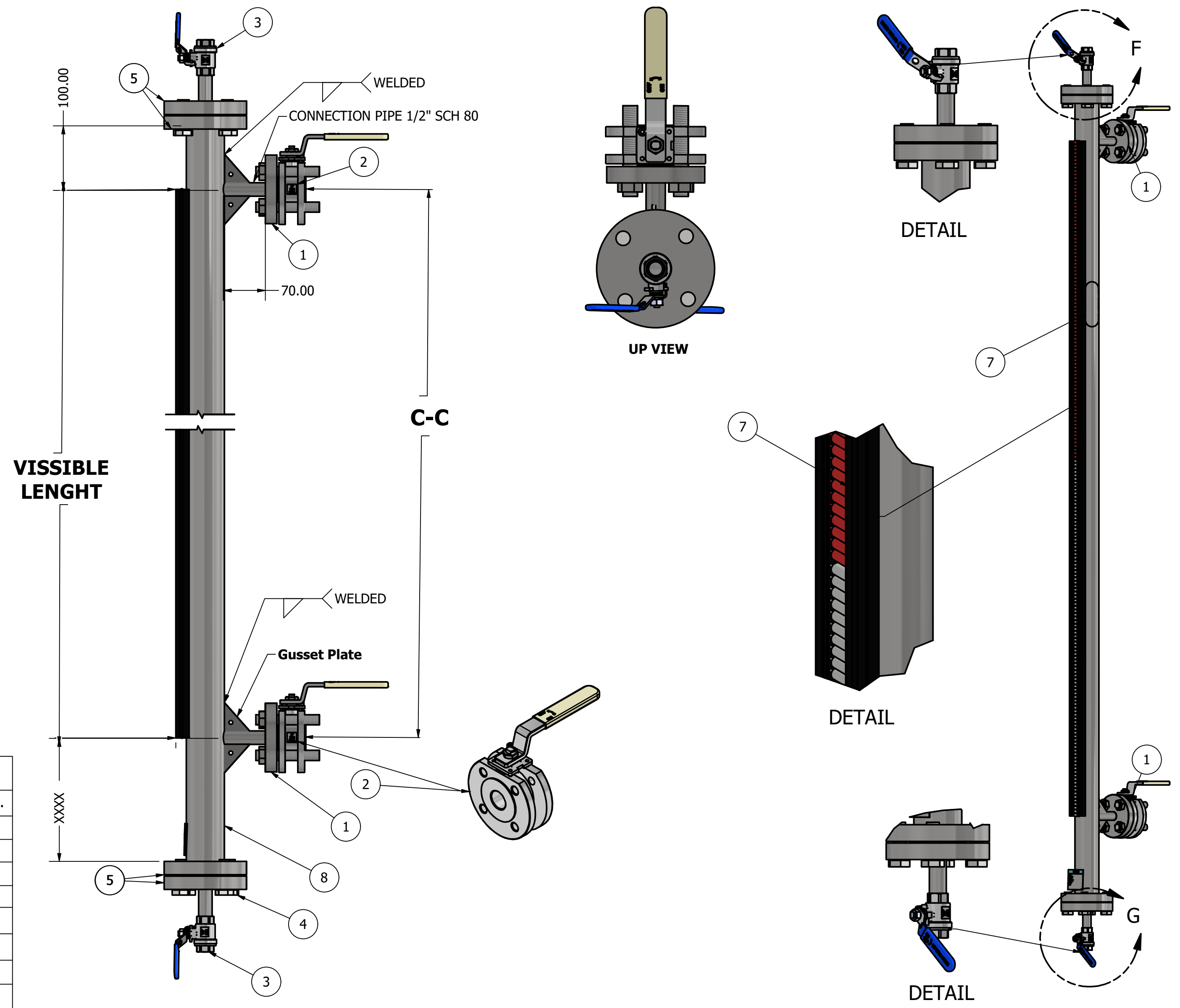

PART LIST			
ITEM	DESCRIPTION	Material	QTY.
1	FLANGE RF	S.S 316	2
2	VALVE WAFER TYPE FLANGED	S.S 316	2
3	BALL VALVE 1/2"	S.S 316	2
4	BOLT		8
5	FLANGE (ARAMAK STANDARD)	S.S 316	4
6	MAGNETIC FLOATER	TITANIUM	1
7	INDICATOR	ALUMINIUM	1
8	MAIN PIPE 2"	S.S 316	1

DESCRIPTION: **MAGNETIC LEVEL GAUGE**

DRAWN BY: **MR.Yadegary**  
 CHEKED BY: **MR.Zarrineh**  
 DESIGNED BY: **MR.zalpour**

2025/10/28  
 2025/10/28  
 2025/10/28

PURCHASE:  
 NOTE:  
 Drawing no t to scale  
 Unit:mm



**ARAMAK SANAT HOOSHMAND**

Rev:01 [WWW.ARAMAKCO.COM](http://WWW.ARAMAKCO.COM) EMAIL: SALES@ARAMAKCO.COM